

PIZZY MONO 105.105
Electric Pizza Oven



EXTERNAL CONSTRUCTION

- Structure in shaped stainless steel
- Door with bottom hinge
- Tempered glass element
- Control panel on front right hand side
- Exhaust steam chimney in stainless steel plate

INTERNAL CONSTRUCTION

- Refractory brick cooking surface
- Top and side structure in aluminised steel
- Rock wool heat insulation

FUNCTIONING

- Heating by armored heating elements
- Heating elements separate survey by thermostat
- Max temperature 450°C
- Continuous temperature survey by mean of a probe

STANDARD EQUIPMENT

- Lighting system by mean of incandescent lamp

**OPTIONS AND ACCESSORIES
(WITH SURCHARGE)**

- Leavening prover on foots, height 1000 mm
- Stand without tray holder, height 700 mm
- Stand without tray holder, height 900 mm
- Four castors kit
- Additional tray holder slides for prover
- Stacking kit



MORETTI FORNI S.P.A.
www.morettiforni.com
e-mail: marketing@morettiforni.com
Via A.Meucci, 4 - 61037 Mondolfo (PU) ITALIA
Tel. +39.0721.96161 - Fax +39.0721.9616299

Pizzy Mono 105.105

(assembled with stand height 900 mm)

TOP VIEW

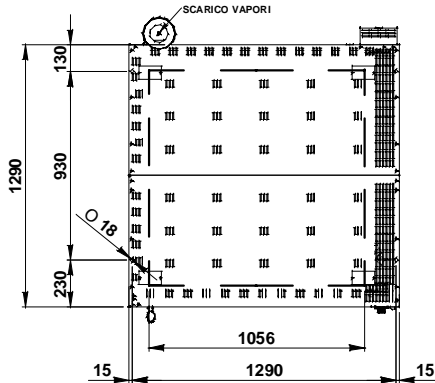

REAR VIEW

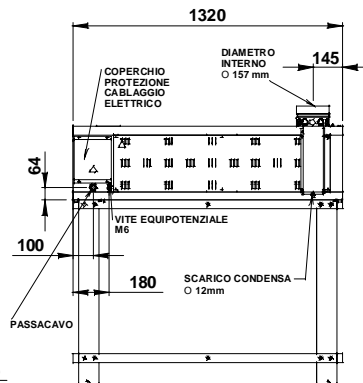

RIGHT SIDE VIEW

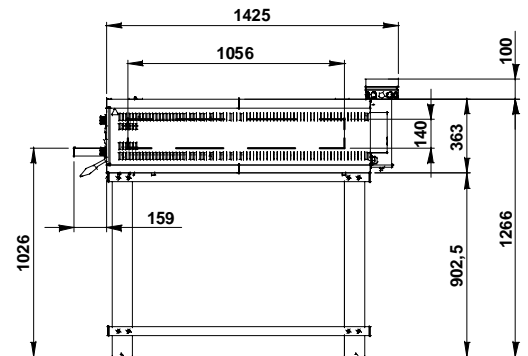

Note: The dimensions indicated in the views are in millimetres.

SPECIFICATIONS

The appliance comprises one cooking element and an optional leavening compartment or support. The oven cooking surface is made of refractory material that provides perfectly even heat distribution over the whole surface, making this oven particularly suitable to cook pizza, either directly on the surface or in trays. Temperature adjustment is electromechanical, with independent control of the ceiling and floor heating elements. The oven door is hinged at the bottom, with a tempered glass window to check the state of the product while it is cooking. The stand comprises a painted metal structure, whereas the leavening compartment has a stainless steel structure and is fitted with a heating thermostat. The leavening compartment can reach a maximum temperature of 65°C, whereas the maximum temperature of the baking chamber is 450°C.

All the data here under indicated are referred to the composition with 1 baking deck

DIMENSIONS

External height	463 mm
External depth	1425 mm
External width	1320 mm
Weight	135 Kg
Total baking surface	1.15 m ²

SHIPPING INFORMATION

Packed oven:	
Max height	545 mm
Max depth	1549 mm
Max width	1409 mm
Weight	(135+23) Kg

FEEDING AND POWER

<i>Standard feeding:</i>	
A.C. V 400 3N	
<i>Feeding on request:</i>	
A.C. V230 3	
Frequency	50/60 Hz
Max power	11.6 Kw
* Average power cons. 5.8Kw/h	
Connecting cable	
tipo FG7R	
5x6 mm ² (V400 3N)	
4x10 mm ² (V230 3)	

TOTAL BAKING CAPACITY

Pizzas diameter	280 mm	9
Pizzas diameter	500 mm	4
Tray (450x 450) mm		4

<i>Prover feeding</i>	
A.C. V 230 1 N 50/60 Hz	
Max power	1.5 Kw/h
* Average power cons. 0.8 Kw/h	

* This value is subject to variation according to the way in which the equipment is used

- 2 -NOTE: Moretti Forni Spa reserves the right to modify the characteristics of the products illustrated in this publication without prior notice